

# Tisas®

[www.tisasarmsusa.com](http://www.tisasarmsusa.com)



USER MANUAL HANDLING & SAFETY INSTRUCTIONS

US

1911 SINGLE STACK SERIES

**READ THE INSTRUCTIONS AND WARNINGS IN THIS MANUAL CAREFULLY BEFORE USING THIS FIREARM;  
DO NOT DISCARD THIS MANUAL.**





## WARNING

Please read this user manual carefully before using the firearm.

Do not use this firearm until you fully understand all of the safety instructions and handling procedures.

## NOTE

Should you require further information, please call a Tisas representative at (404) 590-0851



## INDEX

GENERAL WARNINGS	5
BEFORE USING YOUR FIREARM	8
MAJOR COMPONENTS	10
OVERVIEW OF THE SAFETY MECHANISMS	11
LOADING	13
FIRING	14
UNLOADING	15
DECOCKING THE HAMMER	16
TROUBLESHOOTING	17
DISASSEMBLY & ASSEMBLY	20
CLEANING AND MAINTENANCE	24
PARTS LIST ZIG M1911 - ZIG M1	26
EXPLODED DIAGRAM ZIG M1911 - ZIG M1	27
PARTS LIST ZIG M1911 D10 - L10	28
EXPLODED DIAGRAM ZIG M1911 D10 - L10	29
PARTS LIST ZIG M45	30
EXPLODED DIAGRAM ZIG M45	31
WARRANTY	32

## GENERAL WARNINGS

- \*Read this user manual carefully before using the product.
- \*Do not use any firearm before reading the safety rules and maintenance instructions.
- \*Obey the laws in your country referring to firearms purchasing, carrying and use.

All firearms are dangerous. Tisas is not responsible for any damage that results from the improper use of your firearm.

## ESSENTIAL FIREARM SAFETY GUIDELINES

These firearm safety guidelines have been prepared by Tisas, based upon currently available information. They are provided to you as a courtesy and in the interest of furthering safety. These guidelines are not comprehensive, nor do they modify or replace rules, recommendations, standards, or regulations made by legal authorities or manufacturers.

As a responsible firearms manufacturer, Tisas believes that no issue is more important than firearm safety. We urge you to learn and practice the following guidelines and to make them your habit when handling firearms. This will help ensure safe handling of your firearm(s) and help prevent accidents. We also encourage you to complete an approved firearms safety-training course.



## THE 3 CARDINAL FIREARMS SAFETY RULES

### 1. Always treat a firearm as if it is loaded

Even if you know the firearm is unloaded, always assume it is loaded. The first thing you should do when you receive your gun (pointed it in a safe direction) is to pull back the slide set and visually inspect the chamber to determine whether your gun is loaded or not. If you don't know how to do this, don't use your gun. Note that removing the magazine does not guarantee that the firearm is unloaded because there may be a bullet in the chamber.

### 2. Always keep your finger out of the trigger guard and off the trigger until you are ready to shoot your target

Do not place your finger inside the trigger guard until you have placed a firearm's sights on your target and have decided to fire. The best place to rest your finger in the meantime is above the trigger guard along the frame. By waiting until you are aimed at your target, if the trigger were to be pressed, you will guarantee that a shot will travel safely in the direction of your intended target.

### 3. Always point the firearm in a safe direction in front of and around your target

It is important to identify your actual target, but it is just as important to know what lies in front of and behind your target. A safe direction is any direction where an unintentional discharge or miss will not cause injury or damage. In determining a safe direction, remember that a round can ricochet off an object like a floor, water or wall, or go through walls, floors, ceilings, and windows. Whether in a house or outdoors, the safety direction is the muzzle angled down toward the floor. And never point at or cross the muzzle of a firearm (loaded or unloaded ) at any part of any person's body-the laser rule!

## **ADDITIONAL FIREARMS AND AMMUNITION RULES**

### **ALWAYS KEEP CHILDREN AND OTHERS SAFE BY STORING FIREARMS SECURE AND AWAY FROM UNAUTHORIZED PERSONS**

You should always store firearms and ammunition out of the sight and reach of children and anyone else who is not an intended user or not physically or mentally capable of handling and using them properly and safely. Store firearms in a safe storage place - ideally, one you can lock.

### **CAREFULLY READ THE ENTIRE INSTRUCTION MANUAL THAT COMES WITH YOUR FIREARM**

You should only use a firearm if you fully understand how to safely operate it. All firearms come with an instruction manual created by the manufacturer. If the firearm does not come with an instruction manual, contact the manufacturer directly and request one.

### **ALWAYS MAKE SURE YOUR GUN IS OPERATING SAFELY**

Before shooting, make sure the firearm is in good your gun is working order, that the barrel is clear, and that the firearm is safe to operate. This is especially important when handling a firearm that has been stored or unused for a long period of time.

### **ALWAYS USE CORRECT AMMUNITION**

Never use improper or, incorrect ammunition. Only use ammunition that is recommended by the firearm manufacturer the caliber of your firearm. Most firearms have the caliber engraved or stamped on the barrel. Your ammunition should have the exact same caliber. Additionally, it voids your warranty.



### **WHEN CLEANING THE FIREARM, MAKE SURE IT IS NOT LOADED**

One of the most common statements following an accidental discharge is: "I was cleaning the firearm and it went off!" When you clean a firearm, make sure it is not loaded. You should keep the ammunition in another room until you have finished cleaning the firearm and are ready to reload.

### **NEVER USE A FIREARM WHILE USING DRUGS OR ALCOHOL**

When you handle firearms, your judgment must not be impaired. You should never handle firearms while under the influence of alcohol, illegal drugs, or while using legal prescription medication that can make you tired or affect your senses, reflexes, or judgment.

### **USE EYE AND EAR PROTECTION**

Always wear proper eye and ear protection while shooting firearms, ear protection will help prevent hearing loss from the extreme decibel level of gun fire, and eye protection will help prevent ejection gases, ricocheted objects, casings, or any foreign objects from damaging your eyes. Be smart, be safe.

## BEFORE USING YOUR PISTOL

Your TISAS pistol is semi-automatic, meaning that it is automatically reloaded and ready to fire again after each shot.

Your TISAS pistol can fire even without a magazine inserted. For that reason, ejecting the magazine or inserting an empty magazine does not make your firearm safe. Rather, to ensure your firearm is safe, you must eject the magazine, empty the chamber, and then visually inspect the chamber to ensure no cartridge or other obstruction is present.

Possess, carry and use your pistol in accordance with all relevant local, state, and federal laws. If you purchased this firearm secondhand, have it checked by a qualified armorer or gunsmith to ensure it is safe operate.

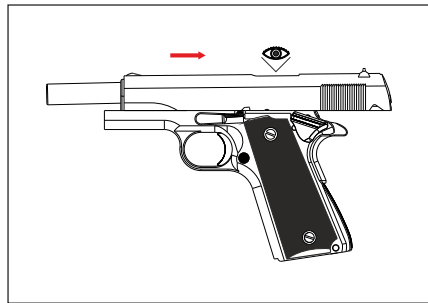

### **⚠ ATTENTION**

Keep your firearm in a safe to operate place where children cannot access it. Always store your firearm unloaded and store the key to the lock separately from the ammunition.



**⚠ IMPORTANT**

When you are not using your gun, you can use a lock to prevent unauthorized use. To prevent use, the magazine of the gun should be removed and the lock should be used as shown in the picture.

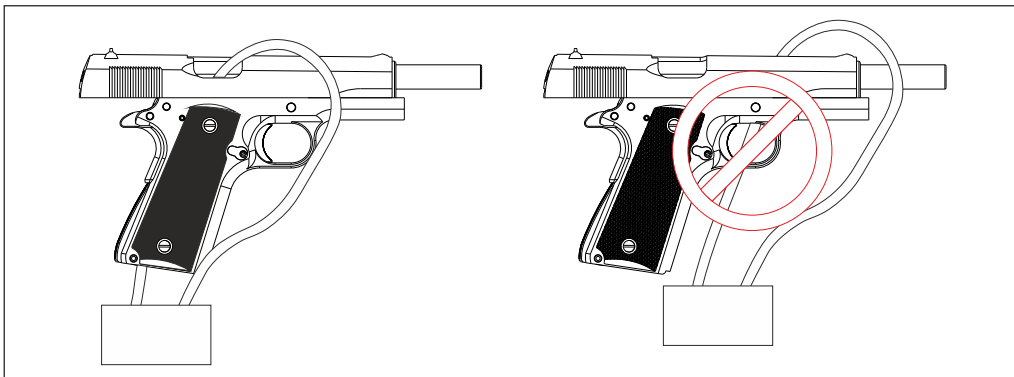

# MAJOR COMPONENTS

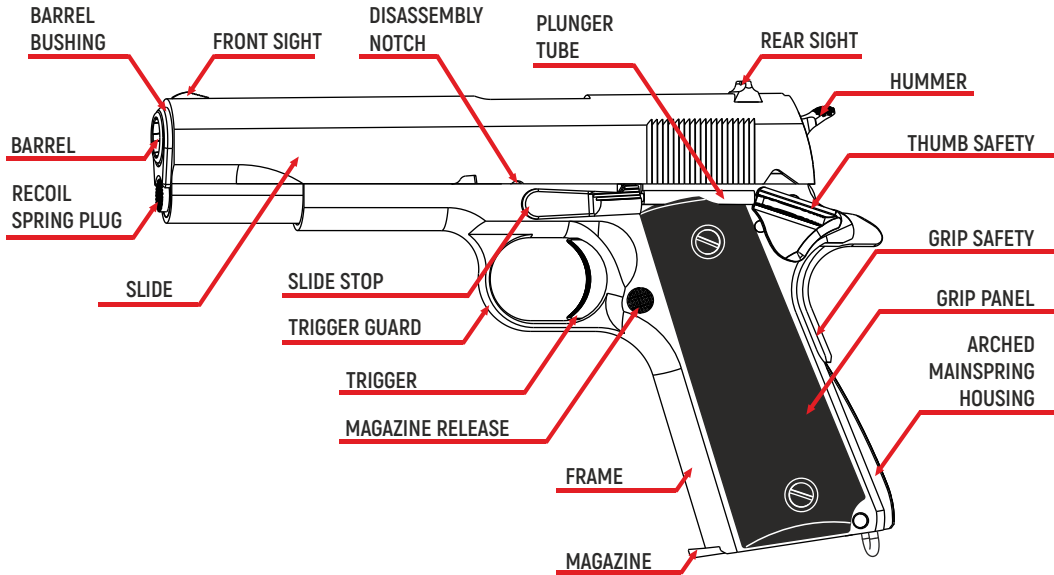



## OVERVIEW OF SAFETY MECHANISMS

Your Tisas pistol is equipped with a grip safety. When engaged, this safety feature provides a block in front of the trigger mechanism that prevents firing.

When the shooter grips the pistol firmly, this safety feature disengages and ceases to present a barrier to firing. However, disengagement of this feature has no bearing on the other safety features. In order for the pistol to fire, the thumb safety must also be disengaged. The thumb safety (2) can be engaged and disengaged when the hammer (1) is in the cocked position. However, when the hammer is in the forward position, the thumb safety cannot be engaged or disengaged.

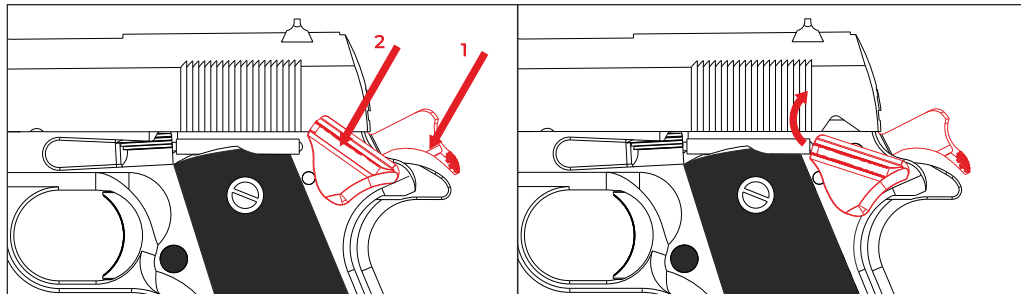

The hammer safety is engaged selector when the hammer is cocked and the thumb selector lever is switched into the up position. When the hammer is not cocked, this safety cannot be engaged, however, it can be engaged if the hammer is half-cocked.

If the hammer is fully-cocked and you want to engage the hammer safety, do the following:

- \* Safely unload the pistol and perform an inspection to ensure you have done so.
- \* Grip the pistol firmly and point it in a safe direction.
- \* While grasping the hammer firmly between two fingers, squeeze the trigger, and slowly guide the hammer to its half-cocked position.
- \* Lock the hammer by use of the thumb safety selector.

When the hammer safety is engaged, the hammer will not touch the firing pin.

### ATTENTION

Do not attempt to engage the hammer safety when the chamber is loaded. The pistol will fire if the hammer slips from between your fingers, possibly resulting in injury or death to yourself or others.



## LOADING

After making sure that your pistol is clean, and that the ammunition is clean, dry and of the correct caliber and type, hold the magazine with one hand and insert ammunition cartridges into the magazine with the other hand until the magazine is fully loaded.

Insert the magazine into the pistol, then retract the slide and release it. At this point, the chamber is loaded and your pistol is ready to fire.

### ATTENTION

Always keep your finger off the trigger while loading your firearm, and always point the barrel in a safe direction.

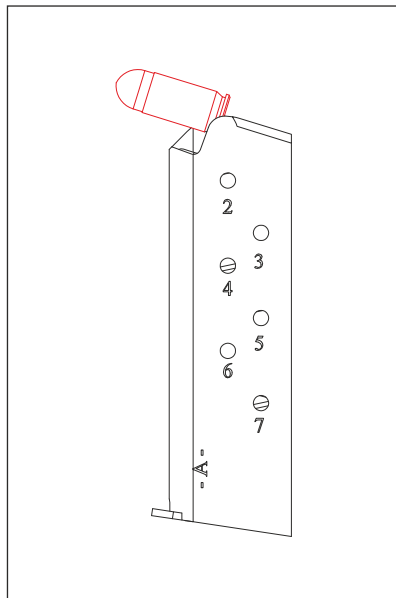

## FIRING

- \*Aim your gun at your intended target and take the appropriate shooting position.
- \*Fix the gun exactly at the target point, at front sight level.
- \*When you are ready to shoot, place your finger on the trigger and pull the trigger slowly. The gun will fire that cartridge and then be ready to fire the next cartridge.
- \*To fire the next cartridge, pull the trigger again and repeat this process until you want to stop firing or until the ammunition runs out.
- \*When the ammunition runs out, the slide mechanism will be locked in the retracted position.

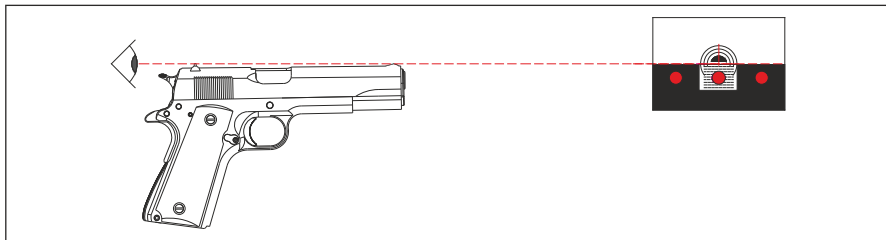

### **⚠ IMPORTANT**

If you are untrained or inexperienced, and have a misfire, a malfunction, or in the event the firearm stops firing before the magazine is empty, unload the firearm and utilize the assistance of a qualified firearms instructor before attempting to operate your Tisas firearm.



## UNLOADING

When the last cartridge in the magazine is fired, the slide locks in its retracted position.

To re-place the slide:

- \* Point the barrel in a safe direction.
- \* Remove the magazine by pressing the magazine release button.
- \* While the slide is in retracted position set back, visually inspect the chamber to make sure it is empty.
- \* By pressing down on the slide stop or pulling the slide slightly backwards, release the slide from the slide stop and slowly release it forward.

If you want to unload the cartridges in the magazine before it runs out, while the slide is in the forward position or the firing pin in the cocked position:

- \* Point the barrel in a safe direction and keep your finger away from the trigger.
- \* Remove the magazine by pressing the magazine release button.
- \* Pull the slide back again and ensure that ammunition comes out of the chamber.
- \* Slowly release the slide to its forward position.

### ATTENTION

Never touch the trigger when loading or unloading the firearm. To ensure the chamber is empty, remove the magazine and then visually inspect the chamber by pulling the slide backwards.

## DECOCKING THE HAMMER

- \* Point the barrel in a safe direction and make sure your pistol is unloaded.
- \* Grip the pistol properly with your dominant hand as if preparing to fire.
- \* Grasp the hammer between the thumb and index finger of your other hand.
- \* Squeeze the trigger and slowly push the hammer until the hammer safety is engaged. Do not release the hammer until the hammer fits into its half-cocked position.

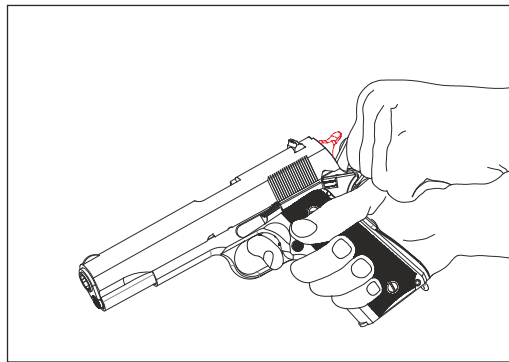

### **⚠ ATTENTION**

Always store and carry your pistol with its chamber empty and its hammer safety engaged. When your pistol is loaded, do not try to release the hammer, as doing so may fire your pistol and cause injury or death to yourself or others.



## TROUBLESHOOTING

### IMPORTANT

To ensure your gun is unloaded, point the barrel in a safe direction, remove the magazine and then visually inspect the barrel chamber by pulling back the slide.

Slide will not lock forward in to battery:

- \* Do not attempt to manually force the slide into battery.
- \* Point your barrel in a safe direction.
- \* Eject the magazine.
- \* Retract the slide to facilitate extraction and ejection of the chambered cartridge.
- \* If the cartridge does not extract and eject, lock the slide in its retracted position.
- \* Inspect the cartridge and carefully attempt manual extraction/ejection. If the cartridge cannot be extracted/ejected, seek the assistance of a qualified armorer or gunsmith.

### ATTENTION

If a bullet is in the barrel, never attempt to shoot it out by using another round. This can generate high pressure, damage the pistol and cause serious injury.

### Unable to fire due to ammunition:

- \* If the slide is not pushed back far enough, the empty cartridge case may not be ejected or the bullet may not be fed.
- \* Stop shooting immediately.
- \* Discharge your weapon safely. Retract the slide and lock it from behind.
  
- \* Check both the barrel and chamber to determine if there is a malfunction.
- \* The low pressure ammunition in the barrel may not have left the barrel, but may have gotten stuck and blocked the barrel. Do not fire the second bullet as soon as you hear the sound of the low-pressure bullet. Therefore, point your gun in a safe direction. Visually inspect the inside of the barrel to verify that the bullet has left the barrel. Firing the second cartridge before the bullet leaves the barrel may disable your barrel and weapon, and may also harm the shooter during the shot. Perform this check following the safety rules for discharging the gun.
- \* If ammunition is not ejected or cannot be removed, lock the slide in the retracted position.
- \* Inspect the cartridge and carefully attempt manual extraction/ejection. If the cartridge cannot be extracted/ejected, seek the assistance of a qualified armorer or gunsmith.

### IMPORTANT

If there is an obstruction in the barrel chamber and/or barrel and you continue shooting, this may result in damage to your firearm, physical injuries, and even death to the user and/or third parties. TISAS is absolutely not responsible for any direct and/or indirect damages that may occur due to this and similar wrong and erroneous practices of the users. Additionally, this voids the warranty given to the product.



### **Troubleshooting other malfunctions:**

- \* Replace any damaged magazines or ammunition cartridges.
- \* Inspect and clean the chamber. Clean the magazine.
- \* Clean the thumb safety selector and the cartridge ramp.
- \* If after taking these steps your pistol continues to malfunction, obtain assistance from a qualified armorer or gunsmith.

### **⚠ ATTENTION**

Carry out all troubleshooting operations in a safe location with the firearm pointed in a safe direction.

## DISASSEMBLY AND ASSEMBLY

### Disassembly for Model 1911 A1

- \* Point the barrel in a safe direction and remove the magazine.
- \* Open the slide to ensure the chamber is empty and visually inspect the chamber.
- \* Push the recoil spring in and rotate the barrel bushing 90° clockwise
- \* Remove the recoil spring plug. If the recoil spring is easily removed, do so at this time. If not, leave installed.

#### NOTE

Keep your hand on the recoil assembly as it is under pressure. If the tool is removed, the spring may eject and could lead to injury.

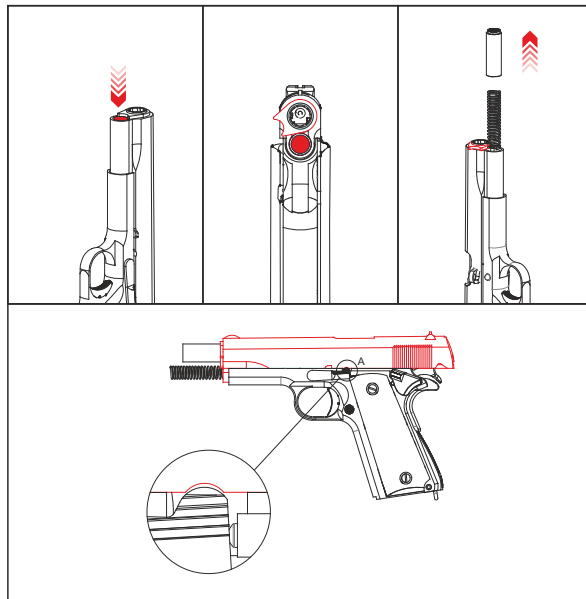



- \* Rotate the barrel bushing back counter clockwise 90° and then 45° further until it can be removed.
- \* Remove the slide stop by slowly pushing the slide rearward until the half moon detent notch lines up with the rear of the stop and then press the stop from the right side and pull out from the left.
- \* Remove the slide by slowly pushing/pulling it forward off of the frame.
- \* Remove the recoil spring guide rod, and recoil spring if it is still installed.
- \* Lift to unlock and then remove the barrel from the slide.

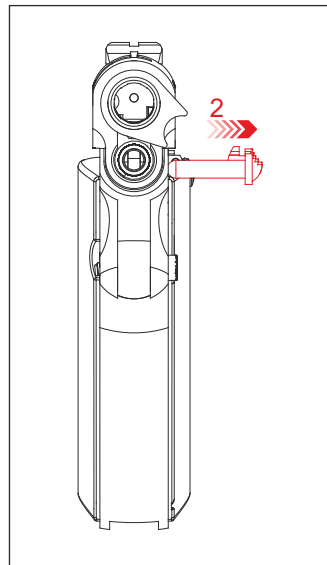

## Assembly for Model 1911 A1

\* Follow the steps for disassembly in reverse order.

### **⚠ ATTENTION**

Take care to maintain firm control of the recoil spring plug during assembly. Failure to do so may result in injury as the recoil spring plug is propelled by force of the recoil spring. Also, ensure correct positioning of the barrel link during reassembly.

### **NOTE**

Ensure correct positioning of the barrel link during reassembly.

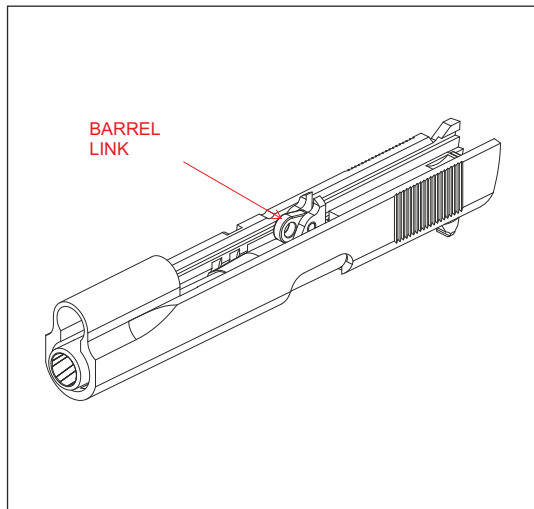



## Disassembly for Other 1911 Models (4.25")

Follow the steps disassembly for 1911 model. (Page 20-21).

### NOTE

Keep your hand on the recoil spring as it under pressure. If you lose your grip, the spring may eject and could lead to injury.

## Assembly for Other 1911 Models (4.25")

\* Follow the steps for disassembly in reverse order.

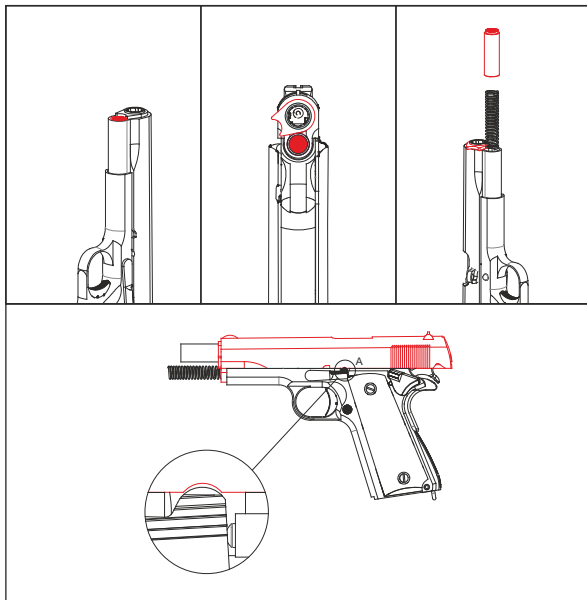

## CLEANING AND MAINTENANCE

To ensure that your gun is always ready to fire and has a long life, follow the rules below and maintain it after each shot, whenever you feel it is affected by external factors such as moisture or dust, or once a month.

Materials required for cleaning:

- \* Cleaning cloth
- \* Gun oil
- \* Brush
- \* Ramrod

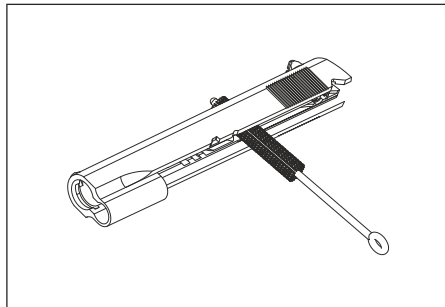

- \* Remove the magazine.
- \* Point the barrel in a safe direction and make sure your gun is unloaded.
- \* Disassemble the firearm.
- \* Remove grips to avoid contact with oil.
- \* Wipe dirty surfaces, parts, slide channels and the inside of the barrel with cleaning oil using a brush.



- \* Do not rotate the brush to the right or left in the barrel, use it linearly.
- \* Lightly lubricate all external parts (except grips) and internal parts with gun oil.
- \* Dry the inside of the barrel with a ramrod.
- \* Dry the exterior surfaces of the firearm with a clean cloth.
- \* Remove excess oil from the firearm's internal working parts.
- \* Reassemble the firearm.

## ZIG M1911 - ZIG M1 PARTS LIST ( A1 MODEL)

NO.	PART NAME	CODE	NO.	PART NAME	CODE
1	MAGAZINE CATCH	C11-1	26	SLIDE STOP	C11-12
2	MAGAZINE CATCH SPRING	C11-1.01	27	BARREL LINK	C11-13
3	MAGAZINE CATCH LOCK	C11-1.02	28	BARREL LINK PIN	C11-13.01
4	MAINSRING HOUSING	C11-2	29	BARREL	C11-14
5	MAINSRING	C11-2.01	30	BARREL BUSHING	C11-15
6	MAIN SPRING CAP	C11-2.02	31	SLIDE	C11-16
7	MAIN SPRING CAP PIN	C11-2.03	32	GRIP PANEL, RIGHT	C11-18
8	MAINSRING HOUSING PIN RETAINER	C11-2.04	33	GRIP PANEL, LEFT	C11-19
9	MAINSRING HOUSING PIN	C11-2.05	34	FRAME	C11-21
10	HAMMER STRUT	C11-3	35	GRIP SCREW	C11-23
11	HAMMER STRUT PIN	C11-3.01	36	GRIP SCREW BUSHING	C11-23a
12	SEAR	C11-4	37	RECOIL SPRING GUIDE	C11-24
13	SEAR PIN	C11-4.01	38	RECOIL SPRING PLUG	C11-24.01
14	HAMMER	C11-5	39	RECOIL SPRING	C11-24.01
15	HAMMER PIN	C11-5.01	40	EXTRACTOR	C11-25
16	REAR SIGHT	C11-6	41	DISCONNECTOR	C11-26
17	THUMB SAFETY	C11-7	42	PLUNGER TUBE	C11-27
18	THUMB SAFETY PLUNGER	C11-7.01	43	FIRING PIN STOP	C11-28
19	SLIDE STOP PLUNGER	C11-7.02	44	LANYARD LOOP	C11-30
20	PLUNGER SPRING	C11-7.03	45	LANYARD LOOP PIN	C11-30.01
21	GRIP SAFETY	C11-8	46	SEAR SPRING	C11-32
22	FIRING PIN	C11-9	47	FRONT SIGHT	C11-33
23	FIRING PIN SPRING	C11-9.01	48	TRIGGER	C11-603
24	EJECTOR	C11-10	49	MAGAZINE	C11-800
25	EJECTOR PIN	C11-10.01			

# ZIG M1911 - ZIG M1 EXPLODED VIEW

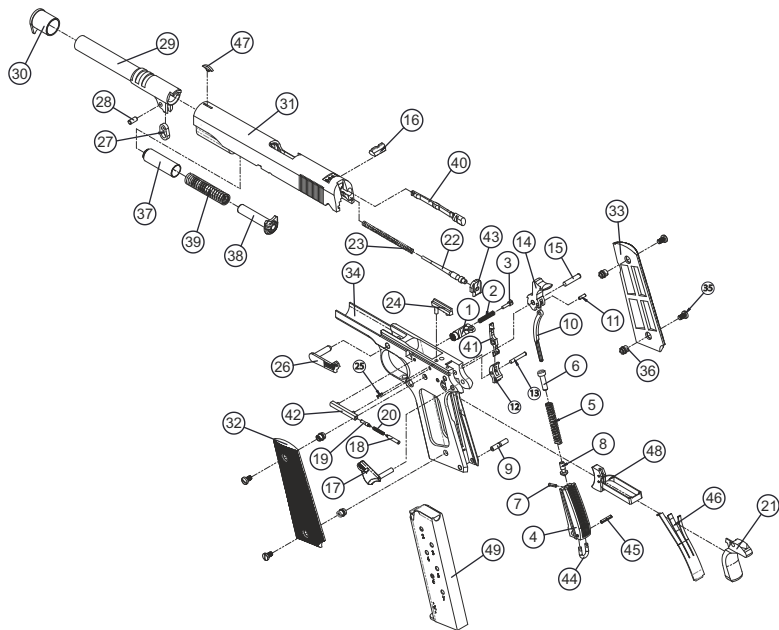

## ZIG M1911 D10 - L10 PARTS LIST

NO.	PART NAME	CODE	NO.	PART NAME	CODE
1	MAGAZINE CATCH	C11-1	26	SLIDE STOP	D10-12
2	MAGAZINE CATCH SPRING	C11-1.01	27	BARREL LINK	D10-13
3	MAGAZINE CATCH LOCK	C11-1.02	28	BARREL LINK PIN	C11-13.01
4	MAINSRING HOUSING	C11-2	29	BARREL	D10-14
5	MAINSRING	C11-2.01	30	BARREL BUSHING	C11-15
6	MAIN SPRING CAP	C11-2.02	31	SLIDE	D10-16
7	MAIN SPRING CAP PIN	C11-2.03	32	GRIP PANEL, RIGHT	D10-18
8	MAINSRING HOUSING PIN RETAINER	C11-2.04	33	GRIP PANEL, LEFT	D10-19
9	MAINSRING HOUSING PIN	C11-2.05	34	FRAME	D10-21
10	HAMMER STRUT	C11-3	35	GRIP SCREW	C11-23
11	HAMMER STRUT PIN	C11-3.01	36	GRIP SCREW BUSHING	C11-23a
12	SEAR	C11-4	37	RECOIL SPRING GUIDE	C11-24
13	SEAR PIN	C11-4.01	38	RECOIL SPRING PLUG	C11-24.01
14	HAMMER	C11-5	39	RECOIL SPRING	D10-24.02
15	HAMMER PIN	C11-5.01	40	EXTRACTOR	C11-25
16	REAR SIGHT	C11-6	41	DISCONNECTOR	C11-26
17	THUMB SAFETY	C11-7	42	PLUNGER TUBE	C11-27
18	THUMB SAFETY PLUNGER	C11-7.01	43	FIRING PIN STOP	C11-28
19	SLIDE STOP PLUNGER	C11-7.02	44	SEAR SPRING	C11-30
20	PLUNGER SPRING	D10-7.03	45	FRONT SIGHT	C11-30.01
21	GRIP SAFETY	C11-8	46	FRONT SIGHT PIN	ZT-3.03
22	FIRING PIN	C11-9	47	TRIGGER	C11-703a
23	FIRING PIN SPRING	C11-9.01	48	MAGAZINE	C11-800
24	EJECTOR	D11-10			
25	EJECTOR PIN	C11-10.01			

# ZIG M1911 D10 - L10 EXPLODED VIEW

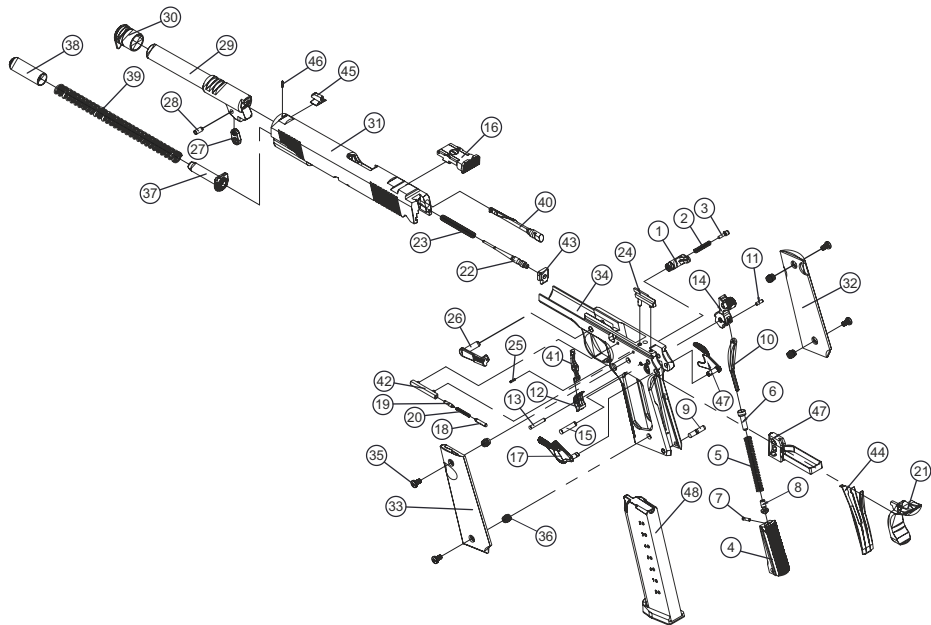

## ZIG M45 PARTS LIST

NO.	PART NAME	CODE	NO.	PART NAME	CODE
1	MAGAZINE CATCH	C11-1	26	SLIDE STOP	D10-12
2	MAGAZINE CATCH SPRING	C11-1.01	27	BARREL LINK	D10-13
3	MAGAZINE CATCH LOCK	C11-1.02	28	BARREL LINK PIN	C11-13.01
4	MAINSRING HOUSING	C11-2	29	BARREL	D10-14
5	MAINSRING	C11-2.01	30	BARREL BUSHING	C11-15
6	MAIN SPRING CAP	C11-2.02	31	SLIDE	D10-16
7	MAIN SPRING CAP PIN	C11-2.03	32	GRIP PANEL, RIGHT	D10-18
8	MAINSRING HOUSING PIN RETAINER	C11-2.04	33	GRIP PANEL, LEFT	D10-19
9	MAINSRING HOUSING PIN	C11-2.05	34	FRAME	D10-21
10	HAMMER STRUT	C11-3	35	GRIP SCREW	C11-23
11	HAMMER STRUT PIN	C11-3.01	36	GRIP SCREW BUSHING	C11-23a
12	SEAR	C11-4	37	RECOIL SPRING GUIDE	C11-24
13	SEAR PIN	C11-4.01	38	RECOIL SPRING PLUG	C11-24.01
14	HAMMER	C11-5	39	RECOIL SPRING	D10-24.02
15	HAMMER PIN	C11-5.01	40	EXTRACTOR	C11-25
16	REAR SIGHT	C11-6	41	DISCONNECTOR	C11-26
17	THUMB SAFETY	C11-7	42	PLUNGER TUBE	C11-27
18	THUMB SAFETY PLUNGER	C11-7.01	43	FIRING PIN STOP	C11-28
19	SLIDE STOP PLUNGER	C11-7.02	44	SEAR SPRING	C11-30
20	PLUNGER SPRING	D10-7.03	45	FRONT SIGHT	C11-30.01
21	GRIP SAFETY	C11-8	46	FRONT SIGHT PIN	ZT-3.03
22	FIRING PIN	C11-9	47	TRIGGER	C11-703a
23	FIRING PIN SPRING	C11-9.01	48	MAGAZINE	C11-800
24	EJECTOR	D11-10			
25	EJECTOR PIN	C11-10.01			

# ZIG M45 - ZIG M9 EXPLODED VIEW

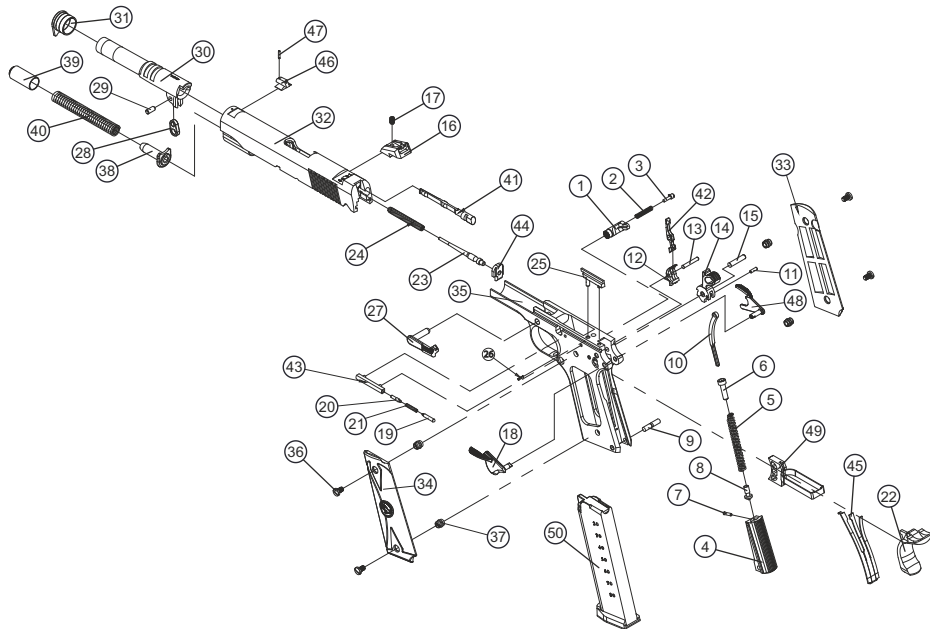

## WARRANTY

At Tisas, we believe in the quality of our firearms, and we want you to as well.

Age and wear cannot be covered under warranty, as the mechanical parts and materials that make up firearms eventually wear out. However, defective parts, materials, and workmanship are not acceptable, and we will stand behind our products. We warrant our firearms to be free from defects in performance and workmanship for five year from the date of purchase. If you have a problem that is directly attributable to the quality of our product, it's on us to make it right, shipping and handling included. However, if you abuse, improperly maintain, or alter the internal workings of your Tisas firearm in any way, we will not warranty damage that occurs. Likewise, if you use improper or incompatible ammunition or parts, we will not warranty damage that occurs. That includes altering a serial number.

If you have a problem with your firearm, please contact Tisas directly at (404) 590-0851 or [help@tisasarmsusa.com](mailto:help@tisasarmsusa.com)

### **RETURN WITHOUT REPAIR**

If we receive your firearm and determine that its damage is unwarrantable, we will contact you with an explanation and an estimation of your cost to have us repair or refurbish it. If you would rather we simply return your firearm to you, we will cover the cost of shipping to do so.

**FREE REPAIR AND RETURN** If your firearm is defective and we determine the defect is warrantied, Tisas will try to repair it. If we repair your firearm, after doing so we will ship it directly back to you, provided you originally shipped it to us from your address. If your firearm cannot be repaired, we will consider replacing it.

### **LIMITATIONS ON WARRANTY**

OUR ONLY RESPONSIBILITY IN THE CASE OF BREACH OF WARRANTY IS REPAIR. TISAS SHALL NOT BE LIABLE FOR ANY OTHER DAMAGES, INCLUDING DIRECT, INDIRECT, OR CONSEQUENTIAL DAMAGES.



PLEASE NOTE: This warranty gives you specific legal rights, and you may also have other rights, which vary from state to state, as some jurisdictions do not allow limitations on certain damages and warranties.

Tisas stands behind the quality of our firearms. While age and wear cannot be covered under warranty, we believe defective parts, materials, and workmanship to be an unacceptable situation. We warrant our firearms to be free from defects in performance and workmanship for one year from the original retail purchase date. If you have a problem that is directly attributable to the quality of our product, we will make it right to include shipping and handling. The Tisas warranty does not cover any issues related to abuse, improper maintenance, the use of incompatible aftermarket parts or any alteration of the internal components. Likewise, damage caused by the use of improper or incompatible ammunition such as reloaded or other non-SAAMI spec ammunition will also void your warranty. Additionally, sales outside of the United States, unauthorized repair, and modifications to the firearm to include altering a serial number, shall not be covered under warranty.

#### **Tisas Lifetime Service Plan**

Tisas is committed to supporting our customers with services that are above and beyond what is expected. Beyond our 1-year warranty, our Lifetime Service Plan will repair any defect in material or workmanship for the lifetime of the firearm. The Tisas Lifetime Service Plan will begin after the 1-year warranty has expired. The Lifetime Service Plan covers material defects; and does not include wear items such as cosmetics, grips, magazines, recoil springs or sights. This Lifetime Service Plan is offered in addition to the 1-year warranty and is not an extension of the warranty.

#### **IMPORTANT WARRANTY INFORMATION**

Tisas pistols are warranted to function with factory produced, SAAMI spec ammunition and the original factory magazine. The use of handloads will void your warranty and the Lifetime Service Plan.

If you do experience a warranty issue, before sending your firearm please contact us at

[help@tisarmsusa.com](mailto:help@tisarmsusa.com) or via phone (404) 590-0851 for a Return Merchandise Authorization number, No firearms will be accepted without pre-approval and completion of this Return Merchandise Authorization.



UPDATED - 2026/02

© ALL RIGHTS RESERVED



2410 Satellite Blvd. NE, suite D Buford, GA 30518  
(404) 590-0851